

# Accepted Manuscript

Tracing sustainable design strategies in the example of the traditional Ohrid house

Radmila Tomovska, Ana Radivojevic



PII: S0959-6526(17)30080-X

DOI: [10.1016/j.jclepro.2017.01.073](https://doi.org/10.1016/j.jclepro.2017.01.073)

Reference: JCLP 8820

To appear in: *Journal of Cleaner Production*

Received Date: 16 January 2016

Revised Date: 11 January 2017

Accepted Date: 13 January 2017

Please cite this article as: Tomovska R, Radivojevic A, Tracing sustainable design strategies in the example of the traditional Ohrid house, *Journal of Cleaner Production* (2017), doi: 10.1016/j.jclepro.2017.01.073.

This is a PDF file of an unedited manuscript that has been accepted for publication. As a service to our customers we are providing this early version of the manuscript. The manuscript will undergo copyediting, typesetting, and review of the resulting proof before it is published in its final form. Please note that during the production process errors may be discovered which could affect the content, and all legal disclaimers that apply to the journal pertain.

## Tracing Sustainable Design Strategies in the Example of the Traditional Ohrid House

**Abstract:** This paper examines the sustainable design strategies of the Balkan vernacular architecture in the example of the traditional Ohrid house. The approach regarding the problem of resource conservation which is present in the selected examples of vernacular architecture offers the possibility of analysing and discussing the building strategies of the past, which are still considered to be relevant in terms of sustainability and environmental design. The subject of this research is the sustainable design strategies that refer to the reuse of building material and the measures regarding waste reduction in the form of its incorporation into new building materials. The research points to sustainable solutions regarding on-site minimisation of construction waste in the example of the traditional Ohrid house during the following three phases of the life cycle of both the material and the building: pre-building, building, and post-building phase. The applied on-site waste minimisation measures and the principle of using materials with low-embodied energy, identified in the example of the traditional Ohrid house, can be understood as the conceptual basis for finding more efficient solutions in today's material and energy conservation practices, proving that sustainable architecture could be achieved by a simple and thoughtful application of local materials and building techniques.

**Key words:** Reuse, on-site waste minimisation, traditional Ohrid house, sustainable design strategies, Ohrid's vernacular architecture.

### 1. Introduction

Contemporary sustainable building practice is looking for a reliable way of assessing and certifying materials. With this in mind, the issue of the use of materials is increasingly being observed through their ecological characteristics that refer to various aspects of interaction between a material and the environment: embodied energy and pollution, waste generation and recycling possibilities, but also the issue of energy conservation and energy efficiency. Contemporary sustainable tendencies reinvent ways for reducing waste and loss of materials, which leads to a reduction of environmental pollution (Zuo and Zhao, 2014; Coelho and de Brito, 2012) Since waste generation on-site is directly related to the design process, better site planning and management of the materials is believed to be the solution

for on-site waste minimisation (Kosmopoulos and Georgiadou, 2012; Osmani et al., 2008). If waste is to become a resource to be fed back into the economy as a raw material, then much higher priority needs to be given to the reuse and incorporation of waste into new building materials (European Commission, 2014).

The importance of the material history is vast and offers possibilities for critical reading, interpretation and development of the concepts related to the transcendental principles and strategies of design and construction (Radović, 1990). The conceptual adoption of the design strategies as regards the reuse and incorporation of waste into new materials, in order to satisfy the needs of today and the future, puts emphasis on the importance of tradition for modern, sustainable architecture. Moreover, relevant material quality in traditional architecture refers to the dependence on local resources which, according to Achenza and Giovagnorio (2015), were usually produced, processed and consumed directly on site, using processes that were consistent with the environmental period in question and supported the regeneration of these materials.

Since material selection, in general, can significantly affect the extent to which a building might be characterised as sustainable (Sassi, 2006) and, on the other hand, the typical approach of traditional architecture was the economy of resources and reliance on local materials, learning and transmitting knowledge from the past to the environmentally friendly contemporary architecture often refers to the recognition, reinvention and transformation of traditional building materials and building technologies (Dayaratne, 2010; Morel, 2013; Pacheco-Torgal and Jalali, 2012;).

Vernacular architecture could be understood as a testimony of the knowledge of the master-builders who built it. Applied vernacular building cultures respected the landscape through the visual aspect of available local materials, the shape and size of a building and its decorative details and its relationships with the environment, demonstrating man's capacity to

adapt to a place, to meet his needs and to address the social and cultural identity of territories (Guillaud, 2015). These houses were usually built by their users together with specialised master-builders and other members of the community, so that the creation of a house was a collective activity, expressing collective needs and values (Radivojević et al., 2012). Sustainable aspects that we might identify today in traditional architecture did not exist as a notion at the time of its creation, but were a spontaneous and instinctive action of its creators.

Knowing that the traditional architecture of the Balkans followed the universal pattern of using locally available building materials (Arun, 2012; Moutsopoulos, et al., 1985; Oikonomou and Bougiatoti, 2011), this research aims to identify the principles of construction and selection of materials applied in the building of Balkan vernacular architecture, which are considered today as the basic strategies of sustainable architecture. More precisely, sustainable design strategies that are in correlation with reuse and waste reduction are analysed using the example of the traditional Ohrid house as a selected representative of Balkan vernacular architecture. With regard to this, the strategies applied in the Ohrid traditional house in terms of the environmental properties of building materials and material flow, i.e. in terms of the re-use and incorporation of waste into new building materials, could serve as a conceptual basis for finding more efficient solutions in contemporary waste minimisation practices.

## **2. Theoretical background**

### **2.1 Basic characteristics of the traditional Ohrid house**

The term Ohrid vernacular architecture refers to the traditional secular architecture of the town of Ohrid, represented by the traditional Ohrid house. This house can be characterised as a regional variant of the Ottoman type of urban house, with specific indigenous characteristics that are specifically related to the spatial plan and structural details

(Figure 1).

Ohrid houses are built on a slope; the terrain having a steep course results in the house lot being very small, narrow and inaccessible. Therefore, the building is usually partially buried, having a vertical superposition of the program content on 3 or 4 levels.

The Mediterranean - continental climate of the Ohrid region requires that the traditional house is organised into two parts – a winter and a summer apartment. The typical architectural expression of the house includes a specific treatment of the yard which becomes a part of the interior of the house, while on the ground floor level the house is closed towards the street. In this way the cellars and the summer kitchen remain in the yard, while the winter residence is on the upper ground floor. The floors of the summer apartment open up to the street, towards the sun and Ohrid Lake. In this way, even though the houses form a very dense urban matrix, the summer apartment enjoys plenty of sunshine, fresh air, and a beautiful view.

The traditional Ohrid house is constructed from various traditional building materials, presented and described in Table 1. Two main building materials - stone and wood, were applied in the two constructive systems: massive stone masonry (lower part of the house representing the winter apartment (Figure 2) and the so-called *bondruk* system (upper parts of the house representing the summer apartment (Figure 3). In this way the house responds in the best way to the climate conditions during the year. The massive masonry system was comprised of stone walls (50-70 cm thick), made of stone blocks and usually bonded with mud as the most common binder, although lime mortar was also applied. These walls were properly stiffened and levelled with a system of wooden beams called *santrač* (Figure 2). The stone masonry represents a very durable structure, while the so called *bondruk* system is a light wooden structure, constructed of basic timber frames consisting of post and beam structures with trusses or braces supporting at the corner points (Figure 4). This type of

timber frame was widely applied, since it allowed the houses to be built quite quickly and the timber material did not have to be of a top quality (Radivojević et al., 2014). The very concept of the *bondruk* structure, as well as the application of timber lacing of the massive stone wall were building techniques that provided good seismic resilience to these structures (Arun, 2014; Papadopoulos, 2013).

The Ohrid house has a *bondruk* wall which is, to some extent, peculiar; an 18 cm thick wall that is a combination of two layers of plastered, closely spaced slats, nailed on both sides of the wooden frame and with an intermediate air layer (Figure 3) (Čipan, 1982, Hadžieva Aleksievska, 1985). Such a wall structure resulted in the creation of a very light construction. The external face of the *bondruk* wall was plastered with a traditional “*čok*” plaster, while lime based plaster was applied on the internal face of the wall. A similar wall structure exists in some parts of Turkey where it is known by the name “*bağdadi*” wall (Arun, 2012). The lightweight *bondruk* structure enabled part of or the whole length of the floor structure to overhang the line of the ground floor (Figure 4), transforming the usually irregular shape of the ground floor plan into a regular form in the upper parts of the house (Figure 5).

## 2.2 Conceptual framework of sustainable design

In spite of the fact that there is a growing awareness of sustainability in architecture, there is still no clear and universal definition and explanation of the notion, assessment and methods for its achievement. A large number of authors in the field of sustainable theories discussed the aforementioned issues and submitted various conceptual and methodological frameworks for sustainable design and construction, discussing different aspects and categories (Zuo and Zhao, 2014), strategies (Sassi, 2006), principles and methods (Correia et al., 2015; Kim and Righton, 1998; Çelebi, 2003).

An interesting approach that has established key principles regarding vernacular knowledge and its contribution to sustainable development was established in the conceptual framework of sustainable design that resulted from the VerSus project.<sup>1</sup> This recent project defined three dimensions of sustainability - environmental, socio-cultural and socio-economic, learned from the vernacular heritage that were analysed through a system of principles and strategies (Correia et al. (Eds.), 2015).

Generally speaking, the goal of sustainable design is to find architectural solutions that enable the well-being and coexistence of organic and inorganic groups (Yeang, 1995). In order to meet this goal, a system of ideas regarding the comprehension of sustainable architecture is established based on the premise that a building must integrate the three principles of Economy of Resources, Life Cycle Design, and Humane Design into the design, construction, operation and maintenance, and recycling and reuse of architectural resources (Kim and Righton, 1998; Çelebi, 2003). These principles are the basis of the conceptual framework of sustainable design (Kim and Righton, 1998), each of them embodying a unique set of strategies. Understanding and implementing these strategies in the design process leads to an improvement of the interaction between the architecture and the environment.

### **2.3 Frugality and rational approach of Ohrid builders**

The master-builders of traditional Ohrid houses had a very thoughtful approach regarding the consumption of building materials that were available at the time of creation of Ohrid vernacular architecture. Materials were selected and incorporated in an optimal way regarding their quantity and suitability, but such a rational choice of materials never endangered the comfort of living in a traditional Ohrid house. The manner in which building

---

<sup>1</sup> VerSus (Vernacular Knowledge for Sustainable Architecture) project is a European research project that was developed from 2012 to 2014 in the framework of the EU Culture 2007-2013 programme.

materials or entire elements were constructed and interconnected suggests that the builders thought in advance about the possibilities and methods of their re-use (Hadžieva Aleksievska, 1985), spontaneously saving in this way the virgin resources of building materials.

Concern and a rational approach was evident starting from the whole building. In the old town of Ohrid, when a house was abandoned by its primary occupants, or if the *bondruk* part of the house was in very bad condition or had burned in a fire, there was a common principle that new the occupants repaired only the parts that were not in good shape (Čipan, 1982). They did not tear down the complete structure nor build a completely new house. On the contrary, they performed all the necessary repairs of the existing structure and-adjusted it to their needs and living habits (Grabrijan, 1986).

Some of the materials used in the construction of an Ohrid house possess the features of the so called recycled content (Kim and Righton, 1998). In the analysed case, the traditional plasters applied to the interior and exterior surfaces of the *bondruk* wall of Ohrid houses can be characterised as materials produced partially from construction waste.

The possibility of recycling natural materials such as wood, clay tiles, and glass is easy and a common practice in today's industry for the production of building materials. In the period between the eighteenth and the beginning of the twentieth century, there was no possibility for recycling materials. However, from today's point of view, the materials implemented in the traditional Ohrid house can be easily dismantled, sorted into common groups of materials, and recycled or, in some cases, re-used in their existing form.

In order to protect a certain building material and to extent its durability in this way, or in order to enhance the material's workability, Ohrid builders used materials such as animal fibre, oil, vinegar, wax, etc. that were available at that time, but which today can be characterised as non-conventional. These measures confirmed the rational approach of



traditional builders who saved in this way either material resources or energy needed for the transport and building process, and today are understood as material conservation strategy.

### **3. Research methodology**

In the quest for elements of sustainability in the traditional houses of Ohrid, the initial phase of the research refers, on one hand, to an interpretation of the basic theoretical and methodological concepts and notions of sustainable design, and an interpretation of collected historiographic data about relevant traditional buildings, on the other. The information database of traditional Ohrid houses was created from analyses of 47 houses, among which were examples of still existing buildings which were analysed on site, while those that have disappeared over time were investigated on the basis of preserved documentation and published works of respected researchers of traditional Macedonian architecture (Čipan, 1982; Hadžieva Aleksievska, 1985; Grabrijan, 1986). The revealed information referred to the basic features of traditional Ohrid houses: their builders, building techniques, modular coordination, standardisation and type sorting of the elements of construction and finalisation that were typical of the analysed vernacular architecture. Further systematisation and interpretation of collected data was performed, in order to identify the applied sustainable principles, strategies and methods.

The conceptual framework of sustainable design created by Kim and Righton (1998) was selected as the most appropriate for the intended identification of sustainable principles of construction and selection of materials used in the traditional Ohrid house that were determined by logical argumentation. The next step of the research involved the correlation between the characteristics and building principles of the traditional Ohrid house and sustainable principles, strategies and methods. The sustainable methods implemented in the example of the traditional Ohrid house are presented in Table 2. Special interest was shown to sustainable strategies and methods applied in the example of the traditional Ohrid house

which derive from the properties of construction materials and that are in correlation with the re-use of building materials and minimisation of construction waste.

Based on a material's life cycle, three groups of criteria are identified. The selection of criteria includes sustainability with regards to a wide range of environmental issues: raw material extraction and harvesting, manufacturing processes, construction techniques, and disposal of construction waste. The criteria that are used in the course of evaluating the environmental sustainability of a material in the pre-building, building, and post-building phase are used in the research in order to determine and compare the sustainable qualities, i.e. "green features" of the building materials used for construction of the traditional Ohrid house (Table 3). The term "green features" of a building material refers to the sustainable qualities of a particular material that was designed, manufactured, and applied with environmental considerations (Kim and Righton, 1998). The presence of one or more of these features in a building material can assist in determining its relative sustainability. One can conclude that almost all of the analysed building materials of the traditional Ohrid house, except glass, indicate the presence of a number of "green features" which characterises them as sustainable building materials.

The conservation practice that was performed on some traditional Ohrid houses in recent times was commented on, referring to identified sustainable building principles of traditional Ohrid houses which are recognised as a particular value of the analysed Balkan vernacular heritage that should be preserved and applied as a method of conservation.

Finally, the identification of green features in the example of the Ohrid house was observed in the light of a conceptual basis for contemporary sustainable building practice which relies on vernacular building principles. Therefore, the revealed traditional building principles that refer to the use of building materials are correlated and compared with building practices of modern residential buildings that are currently constructed in the town

of Ohrid. For that purpose, 20 houses that were built in the upper part of the town at the end of the 20<sup>th</sup> century are analysed and compared with previously analysed traditional houses.

## **4. Results and discussion**

### **4.1 Green features applied in the pre-building phase**

Many green features of a building depend on the way the building was conceived and its construction methods, i.e. the structures and building materials that were selected.

Therefore, correct decisions and actions in the pre-building phase might contribute to a great extent to the achievement of overall sustainability.

#### ***4.1.1 Source reduction by design***

In general, material conservation strategy in the pre-building phase includes source reduction by design as a process that reduces the demand on virgin resources. This method relates directly to the programming and design phases of the architectural process. Our present knowledge indicates that the architect has an important role in the minimisation of construction waste (Osmani et al. 2008; Poon et al., 2004). Recently, several studies have indicated the importance of the design stage. It has been estimated that 33% of the on-site waste is due to the architect's failure to implement waste reduction measures during the design stages (Innes, 2004; Osmani et al, 2008), since architects attached relatively little importance to the potential for waste reduction during the design concept and building material selection phase (Poon and Yu, 2002). Hence, resource-efficient construction strategies, which simplify the building's shape, use standard material modules and provide for a building's growth and change, and increase material efficiency by design, offering an introspective and upstream approach to source reduction and waste prevention. Since buildings could be understood as an accumulation of materials, contemporary design strategies, such as design for disassembly, or design for reuse, have become increasingly

important in the manufacturing sector. Their implementation requires the application of standard dimensions in the design process and selection of materials.

Corresponding building methods used in the past by the Ohrid master-builder are standardisation and type-sorting of elements of construction and finalisation. In the example of the traditional Ohrid house, this is expressed through multiplication of the basic measure – *aršin* (Hadžieva Aleksievska, 1985).<sup>2</sup> Multiplication of the basic measure facilitates the process of composing, combining and resolving the constructive issues for the builder. Due to the use of coordinated dimensions, while using primitive technical tools, the builder's method took on the character of modular coordination (Figure 4). Thus, it became the key for the dimensional compatibility of the whole vs. details. The result of this approach enabled compatibility of the built-in elements, built-in furniture, windows, doors, stairs, fences, etc., with the whole *bondruk* constructive system. Proper sizing and standardisation of the constructive system represents a waste reduction measure during the design process.

The modular coordination in the horizontal and vertical plans of the Ohrid house offered the possibility for reusing building material still in good shape, after the useful life of the building had ended. The master-builders used the same module (*aršin*) for all the objects they built. Thus, prior to the demolition of an older building, the identified useful building materials and elements of finalisation were carefully removed from the building, sorted and then incorporated into a new one. This method, nowadays known as sustainable design strategy or *Design for Reuse*, is widely applied in waste minimisation practice (Kim and Righton, 1998; Çelebi, 2003)

---

<sup>2</sup> The *aršin* is an anthropomorphic measure with a length determined by the distance from the shoulder joint to the end of the middle finger of the outstretched hand. The *aršin* was both an instrument and a standard unit (module), which resulted in a system easily adaptable both to construction techniques and to the spatial conception of the buildings.

Type-sorting refers to the established rules in creating standardised forms for solving particular details, contributing to the achievement of compatibility of the elements. It is significant to mention the type-sorting of the ceiling elements from the representative rooms of Ohrid houses. A lot of time, effort, and high quality materials were needed to produce the famous carved ceilings from the second half of the 19<sup>th</sup> century (Figure 6). Furthermore, due to the fact that this ceiling element had large dimensions, the master-builder was considering the method of mounting and disassembling from the very beginning of the design process. This practice enabled a new installation of the same carved ceiling in another building, as in the case of the representative ceilings of the famous Urania house, which was primarily placed in another house and then transferred and installed in one of the representative lounges of this house (N.U. Zavod i Muzej Ohrid, 2010a). Such a sustainable approach saved, to a great extent, both time and resources, simultaneously representing an energy and material conservation measure.

Another building method used by the master-builder which can be understood as a source reduction by design is the correct sizing of the building system. The size of the building is always in correlation with the consumption of materials and energy. Therefore, a building that is designed as oversized, or that has oversized systems, will excessively use materials and energy. In the example of the traditional Ohrid house, the rooms are never oversized. The rational dimensions of the rooms regarding their width and height were anthropomorphically dimensioned, which allowed the inhabitants to function well in those spaces, but at the same time an optimisation of the incorporated building material was achieved.

The Ohrid house has an organic shape corresponding ideally with the natural and built surroundings. The house is usually buried from the north side and it appears as if it is emerging from the terrain (Figure 4). The master-builder was able to optimise resource

efficiency by maximising the building's use and function while minimising its size. Hence, the ground floor of the traditional Ohrid house could be very small, but the vertical superposition of the program content on 3 or 4 levels provided the owners with all the required space in the house (Figure 5).

Flexibility of the building is another material conservation method that refers to the ability of the master-builder of the traditional Ohrid house to produce design concepts and solutions that allowed growth, change of the space plan, and replacement of dilapidated material. Unlike the massive stone walls of the house, the applied *bondruk* constructive system is an anthropomorphically dimensioned system, very elastic in terms of reparation and adaptation of the space plan of a house, hence offering the possibility of constant enlargement and redesign, due to which we will name them "growing buildings". This was a common feature in Ohrid traditional houses which is called "elasticity of the building" (Grabrijan, 1986).

Following this principle, one identifies the usual interventions in the examples of Ohrid's vernacular architecture:

1. Changing the façade's layout: closing windows, adding glass to open balcony (*chardak*), adding additional window openings, etc;
2. Changing the spatial plan of the *bondruk* floor;
3. Changing the position of the staircase;
4. Additional openings into the roof structure and its adaptation;
5. The subsequent change of the woodworks due to the end of their useful life (Čipan, 1982);

Such partial adaptation of certain elements of the constructive system points to another characteristic of the Ohrid house construction: its rationality, i.e. prudence.

#### ***4.1.2 Minimisation of energy needed for distribution of materials***

In the past, the basic principle of construction relied on local resources (Oliver, 1997). From today's perspective, this implies that using locally produced building materials shortens transport distances, thus enabling a reduction of both energy consumption and air pollution produced by the transport. In addition, local materials are better suited to climatic conditions and support local economies (Fernandes et al, 2014; Correia et al., 2015). Materials can be obtained locally, even at the building site itself, as in the case of Ohrid vernacular architecture. Stone, earth, sand, and clay, excavated at the building sites were often used as building materials for newly-built structures. However, when the stone found at the site was insufficient, additional stone from the immediate surroundings and from the nearest quarry was also used.

#### ***4.1.3 Use of materials made from renewable resources***

Some of the materials that were used in the construction of the traditional Ohrid house that are natural and organic, such as the wood used for the construction of the *bondruk* system, or the straw fibre or animal hair that were used as additives in mortars and plasters, can be characterised as coming from renewable resources. The amount of the used renewable building materials was very small and did not unduly disturb the flora and fauna in this region.

#### ***4.1.4 Use of durable materials with low maintenance***

This method reduces the amount of natural resources required for manufacturing, the amount of energy spent during installation and the associated labour. In other words, durable materials that require less frequent replacement will require fewer raw materials and will produce less landfill waste over the building's lifetime (Sassi, 2006; Çelebi, 2003). The

materials of high durability could endure many useful years of service in new buildings in those cases when the useful life of an old building had ended. In cases like this, they could be easily extracted and reinstalled at a new site. In many instances, the quality of materials and craftsmanship displayed by these pieces could not be reproduced today (Kim and Righton, 1998).

Due to its durability, stone was often reused in the past. In the example of the Ohrid house, this practice is confirmed by the reuse of different elements of treated stone from the earlier phases of Ohrid's history, which were incorporated into the more recent massive walls of traditional houses (Figure 7).

Unlike the stone that was incorporated into the massive walls of Ohrid houses, wood, which cannot be characterised as a durable material, was used in the form of beech, which was the most commonly used wood type and, rarely, pine, both from the immediate surroundings. Beech wood is hard and durable and this was the reason for its predominant use as a material in the elements of construction. A significant ecological feature observed in the Ohrid house is the way the wood is protected and its life extended, since wood protection was achieved by the use of natural materials such as: vinegar, oil, wax, tar, etc. (Tomovska and Radivojević, 2015).

#### ***4.1.5 Use of local, natural and non-toxic materials***

Using local, natural and non-toxic building materials, chemically and mechanically treated to a very small extent, is a general building strategy of the Ohrid master-builder. The use of natural materials from the immediate surroundings is a logical solution in the selection of the combined constructive system of the Ohrid traditional house (Čipan, 1982; Grabrijan, 1986; Muličkovski, 2000). Granite, basalt, clay, limestone, beech and fir wood have all played a part in the search for appropriate construction solutions (Tomoski, 1960), with regard to their future position in the building, their exposure to atmospheric and other agents,



and the desirable longevity of the building element.

Natural materials are generally lower in embodied energy and toxicity, in comparison to man-made materials (Berge, 2001; John et al., 2004). From a contemporary perspective, embodied energy, and since recently, embodied carbon, are the most frequent parameters for the estimation of the impact that building materials and the whole building have on the environment (Cabeza et al., 2013). However, there is significant variability of their calculated values due to their dependence on LCA system boundaries, applied technology, the local economy, etc. (Crishna et al., 2011), and in many cases values have been calculated for only a small number of building materials. In this regard, the calculated embodied energy of a stone block when estimated in India, where usually only manual labour is employed for its sizing, is negligible (Ventakarama Reddy and Jagadish, 2003). On the other hand, a recently conducted study shows that in the UK, depending on the type of stone, system boundaries and the use of local or imported stone, the values of relevant environmental indicators varied drastically (Crishna et al., 2011). However, being natural or naturally based, the prevailing materials of the traditional Ohrid house undoubtedly require less processing and are less damaging to the environment (Cabeza et al., 2013; Fernandes et. al., 2014). Therefore, when natural materials are incorporated into buildings or building products they inevitably become more sustainable (Melia et al., 2014).

#### **4.2 Green features applied in the building phase**

Reducing waste in the construction process increases the resource efficiency of the building materials and is a proactive process of preventing scrap materials from entering the air, land, or water. With this approach, it is possible to reduce or eliminate waste at the source (Yeang, 1995). Incorporating the scrap material into new building materials at the construction site improves resource efficiency to a great extent (Poon et. al, 2004). In

addition, reducing construction waste contributes to a reduction of the construction cost and embodied energy (Osmani et al, 2008).

#### ***4.2.1 Incorporation of scrap and useful materials found on the site***

Typical for the traditional Ohrid house was incorporation of the waste, as well as the scrap material in the production of new, useful building materials at the construction site. The scrap material usually comes from various moulding, trimming, and finishing processes, or from defective and damaged products at the construction site. Furthermore, in the example of the Ohrid house, a great amount of waste-stone, sand, and clay is produced in the process of excavation at the location site. This method leads to several waste minimisation techniques applied in the analysed traditional buildings.

Contemporary research of the micro structure of building materials gave answers to many questions regarding the ancient manufacturing technology, as in the case of historic mortars where the presence of inclusions was confirmed (Stefanidou et al., 2012). Two categories of inclusions were distinguished, those that were put into the mortar mixture intentionally (such as wood chips, straw, etc.), in order to improve their final properties, in quantities that varied depending on the type of mortar and historical period, and those that could be understood as impurities in the raw materials.

In a specific way, such a practice was present in the case of the mortars and plasters that were applied in the traditional Ohrid house. The incorporation of shavings into the “čok” plaster mixture was a well-known building technique used by master-builders during the construction of the traditional Ohrid house. It was usual that the process of preparation of the building materials took place at the building site. Such a building strategy allowed the construction waste, produced at the construction site by the trimming and finishing processes applied to the lumber, to be incorporated into the plaster mixture. This approach not only

reduced the cracking tendency and enhanced the thermal insulation properties of the material, but also reduced the energy needed for the removal and transportation of waste.

The incorporation of powder from clay-tiles into the lime-based plaster was another widely applied technique during the construction of the traditional Ohrid house. Important to mention is the technique of plastering the interior surface of the *bondruk* wall of the traditional Ohrid house. This technique required the preparation of a plaster mixture with good adhesive characteristics. Usually, the plastering of the interior wall was done in three layers. A small amount of pozzolanic material was incorporated into the plaster mixture (ground volcanic stone, powder from clay tiles and/or pozzolanic earth) in every layer, which improved the composition of the plaster mixture (N.U. Zavod i Muzej Ohrid, 2010b). Loose materials from the building site may also have been added as an aggregate.

One could conclude that the traditional external and internal renders of the *bondruk* wall were produced partially from the construction waste. The incorporation of soil and sand from the excavation processes, as well as scrap material (damaged clay-tiles and wood shavings) from the construction processes into the mortar mixture reduces the waste stream and demand for virgin natural resources. This strategy prevails in today's sustainable practice and can be characterised as an on-site waste minimisation measure.

#### ***4.2.2 Use of building techniques that support energy and material conservation***

Optimisation of construction efforts in vernacular habitats is achieved by using appropriate and inventive traditional building techniques and technologies (Oliver, 1997; Correia et al., 2015). Those that were practiced by the Ohrid master-builder which support energy and material conservation are:

1. Manufacturing technology of traditional plasters, already explained;

2. External finishing of the massive wall. In all Ohrid houses, the stone wall was not plastered, but the joints were professionally constructed in several ways: they were concave or convex, sometimes painted in white paint, which created an interesting texture (Figure 8). The specific construction of this wall provided a unique appearance while, at the same time, it saved energy and material in the processing of the stone material. If the stone was processed, a huge amount of this material would have been wasted in order to achieve symmetrical and regularly shaped stone blocks. Furthermore, if the overall surface of the stone wall was plastered, a considerable additional amount of plaster would have been needed. This building strategy enabled the waste prevention and source reduction that improved the resource efficiency of the building process. In addition to saving material, this principle saved human resources and shortened the time needed for constructing the massive part of the house, while the aesthetical qualities of the wall were not lost.

3. Wooden stitching of the *bondruk* wall. Due to the strong southerly wind and the difficulty of bonding plaster to the wooden components of the *bondruk* wall, the plaster soon started to crumble and fall from the wall. Consequently, the master-builder started to apply dark painted wooden stitching in critical areas (Figure 3 and Figure 9), such as the poles at the corners, the beams between the windows and the sides of the floor construction. This kind of solution was applied on both the inner and outer walls, having both a functional and aesthetic role.

#### ***4.2.3 Use of non-toxic materials and cleaners***

The use of non-toxic materials and the maintenance of the building with non-toxic cleaners is vital for the health of the residents. In the period from the eighteenth until the twentieth century, the time of the erection of vernacular architecture of Ohrid, the chemical industry and its products had no big involvement in households. Local, natural, and non-toxic

materials such as stone, wood, soil from the region (clay, sand, pozzolanic earth), animal fibre, straw and glass were incorporated into the traditional house and were, to a great extent, responsible for realising the hygienic comfort of the building. Moreover, some of these materials are biodegradable and are, thus, not toxic for the natural environment. Even the wood protection, nowadays performed with very toxic materials (Berge, 2001), in the case of the analysed traditional house was performed by non-toxic, eco-friendly natural products.

### **4.3 Green features applied in the post-building phase**

The beginning of the post-building phase in the example of the Ohrid house is the moment it house stops being a useful and convenient living place for its occupants. In that moment, in the past, the master-builder would consider all the options for the building's future. In other words, the existing structures as well as the building materials and components that remained in good shape were planned to be used again in another building. Today, architectural reuse processes include adaptive reuse, conservative disassembly and reusing preserved materials (Latham, 2000; Lyle, 1994). In order to be reused, durability is the key feature that the preserved materials should possess (Kim and Righton, 1998). Sustainable strategies applied in this phase are focused on the reduction, re-use or biodegradability of construction waste.

#### ***4.3.1 Reuse of building components and materials***

The traditional dependence on local resources brought with it the habit of reusing materials (Oliver, 1997). In the case of the traditional Ohrid house, the massive wall was usually constructed of untreated and treated stone blocks that often originated from older buildings and monuments that previously existed on the site (Figure 7).

The use of standard dimensions in the design process of the Ohrid house allowed the reuse of the elements of construction and finalisation (Figure 4). When a building had to be demolished, the individual components that were in good condition were selected for reuse - windows, doors, parts of the *bondruk* construction and interior fixtures (wooden panels, slats, pieces of carved ceiling, built-in cabinet flanks, etc.). After selecting the materials to be reused, they were incorporated into the new building being built on the same construction site by the same owner or they were sold to another person building a new house. Due to the so-called principle of modular coordination based on the *aršin* measure that was typical for a traditional Ohrid house, the preserved disassembled materials from one house in the post-building phase were used in the design process of a new house in the pre-building phase (Figure 10). This feature of Ohrid vernacular architecture prevails and is fostered in contemporary sustainable practices.

This kind of building cycle represents a perfect form of circulation of material that is in good shape, and the use of new raw materials and resources is kept to a necessary minimum. Moreover, it is important to mention that the concept and applied joints of the *bondruk* system offered the possibility of replacement of deteriorated material. So, when reused materials were no longer in good shape, they could be easily replaced. This characteristic of the constructive system is very important when choosing a material of limited durability. In the past, when such repairs were conducted, the original type of building material was still abundantly available in the immediate surroundings.

#### ***4.3.2 Reuse of existing parts of the building***

From a historical perspective, a common building principle for the optimal use of existing parts of older buildings was practiced in the Old Town of Ohrid as well as in all the settlements and towns that existed continuously for a long period. In that sense, in the

example of Ohrid vernacular architecture, the stone walls or the walls built in the *opus mixtum* technique from older buildings were usually incorporated into the new building structures as foundation walls or as walls of the massive ground floor in the newly built structure.

#### **4.3.3 Biodegradability of used materials**

Chronologically, Ohrid vernacular architecture is located in the period between the eighteenth and the beginning of the twentieth century. Before the age of industrialisation, materials comprised primarily of stone, wood, grass, and earth. So, the unwanted structures could simply return to the soil (Peris Mora, 2007). In this respect, with regard to the used material, this architecture can be characterised as organic. All the materials used for constructing the Ohrid house, as mentioned earlier, are natural and non-toxic and most of them are organic and safe for the environment when decomposing. Wood, clay, animal hair, straw, “čok” plaster and lime based mortars all biodegrade in a very short period of time.

The local, organic material basis of the house, as well as its biodegradable characteristics, points at the natural cycle of such buildings, which do not endanger the natural environment. These buildings stem from the ground foundations and at the end of their life cycle they go back to the ground again (Figure 11). The concept of the natural cycle of the traditional Ohrid house is in correlation with the sustainable policies of the world’s contemporary architectural companies that are focused on “aligning the construction industry with the cycles of nature” and producing “biodegradable building products that are composted after demolition” (Brooks et al, 1995).

#### **4.4 Correlation between contemporary building and conservation practice and the achievements of architectural heritage in the Old town of Ohrid**

In 1980, the specific value of Lake Ohrid, parts of the Ohrid region as well as the Old town of Ohrid were recognised and affirmed by UNESCO as cultural and natural world heritage sites (ICOMOS, 1980). Although this status was highly respected by authorities and experts until 1990, as a result of the cultural policy of the ex-Yugoslav republic to which Macedonia and Ohrid once belonged, the transitional period that followed brought gaps in the management of cultural policy in the Republic of Macedonia, manifested in violation and disrespect of legislation during the 1990s (Gavrilović, 2006, Nikoloska, 2007). While interventions in the urban tissue of the old town of Ohrid and its immediate surroundings as well as conservation activities on the buildings that were carried out before the transition of 1990s could be characterised as research of quality, the careless attitude towards cultural heritage that followed as a result of existential problems of the population, inefficiency and corruption of local authorities and passive behaviour of the state authorities brought permanent disruption and changes to the image and the silhouette of this town (Trca, 2004). Additionally, building heritage was degraded by the use of inadequate building materials, structural elements and building techniques that were suitable for neither conservation, restoration nor revitalisation of the historic structures, or for the construction of new buildings. After 2004, the state authorities started with the implementation of a more conscientious and responsible policy in relation to the protection of cultural heritage (UNESCO, 2004a; UNESCO, 2004b; UNESCO, 2006), but, in reality, its implementation was far from satisfactory.

The transitional period was not favourable for the authenticity of architectural heritage in the territory of Ohrid, or for the recognition and respect of the values of vernacular building principles, although they can find their practical use in the field of preservation of the cultural heritage of the Balkan's (Gavrilović, 2006; Nikoloska, 2007; Tomovska et al., 2014). The use of traditional techniques and local materials in the



conservation of vernacular architecture is considered to be the result of the thoughtful and advantageous use of means and resources available in the surroundings, with almost no transformation (Correia, M. et al, 2015). However, in the attempts to preserve the form of traditional houses, which were often in bad condition due to the lack of maintenance, the applied conservation measures often included the complete replacement of original building materials and structures with contemporary ones. Such a drastic approach was applied even on the extremely important and valuable examples of traditional houses in Ohrid, such as Uranija House (Tomovska et al., 2014).

Although the building principles of Ohrid vernacular architecture are characterised as sustainable and ecologically correct, and therefore deserve to be applied to and reinterpreted in the contemporary buildings of this region, modern building practice related to the town of Ohrid has manifested their complete ignorance and incomprehension. A comparison of the applied green features in modern and traditional buildings clearly indicates that, in case of the town of Ohrid, vernacular building practice possesses more sustainable features than the modern one (Table 4).

## 5. Conclusion

It can be concluded that the implemented sustainable design strategies and methods that are in correlation with reuse and waste reduction in the example of the traditional Ohrid house are being recognised, especially in the domain of the first two principles of sustainable design: economy of resources and life cycle design. The applied sustainable design methods from the example of the Ohrid house are an integral part of the strategies that include both energy conservation and material conservation during the pre-building, building and post-building phases.

Economy and rationality, as important virtues of the master-builder, contributed to a large extent to finding smart solutions with regard to reuse and on-site waste minimisation.

Even in the pre-building stage, i.e. in the very process of design, due to the organic perception of architecture, the basic, conceptual, foundations of modern sustainable architectural design can be traced. The practice of the incorporation of excavated materials found on the site, as well as reclaimed material and structures into the new building reduced the demand for new material resources, minimised construction waste and reduced energy for transportation. Being typical for the analysed case of vernacular architecture, the frequent reuse of elements of construction, or the so-called design for reuse, was achieved by the use of standard dimensions and modular coordination in the design process, revealing the relevance of this concept for modern, sustainable practices. Another important sustainable strategy seen in this example is the saving of materials and resources by incorporating the waste produced at the building site into new, useful construction material.

The flexible design and organic material basis of the house, as well as its characteristics of biodegradability, reveal the natural cycle of these buildings. The use of local, natural, non-toxic, and biodegradable materials ensures comfort and quality of life during the whole lifecycle of the building. It also enables energy saving in the process of disposing of the construction waste in the post-building phase, contributing to the achievement of the lower embodied energy of the whole building.

Better understanding and respect for the sustainable qualities of traditional Ohrid houses can contribute to a more thoughtful implementation and an enhancement of the quality of conservation work. On the other hand, relying on the local building principles that are characterised as sustainable and their use as guidelines for the design of contemporary Ohrid houses would contribute to the preservation of their uniqueness, authenticity and regional texture and would fit into the proportions and scale of the town. In other words, adapting the regional design and building techniques, using locally available materials

according to modern standards and modern technology, can result in creating outstanding regional examples of sustainable architecture.

## References

- Achenza M., Giovagnorio I., 2015. Environmental sustainability in vernacular architecture, in: Correia, M., Dipasquale, L., Mecca, S. (Eds.), *VERSUS, HERITAGE FOR TOMORROW: Vernacular Knowledge for Sustainable Architecture*. DIDA Dipartimento di Architettura Università degli Studi di Firenze, Firenze, pp. 41-47.
- Arun, G., 2014. Lessons to be learned from ancient building masters. *Journal of SEWC*. 4 (1), 5-11.
- Arun, G., 2012. Traditional timber structures in Turkey, in: *Proceedings of the 8<sup>th</sup> International Conference on Structural Analysis of Historical Constructions SAHC*, Wroclaw, Poland, pp. 995-1002.
- Berge. B., 2001. *The Ecology of Building Materials*. Architectural Press, Oxford.
- Brooks, K., Torone B., Adams, C., Demsetz, L., 1995. Making construction and demolition debris recycling profitable: The roles of public policy and inovative project management, in *Proceedings of the Construction Congress*, by Construction Division of the American Society of Civil Engineers, San Diego, pp. 391-397.
- Cabeza, L., Barreneche, C., Miró, L., Morera, J., Bartolí, E., Fernández, I., 2013. Low carbon and low embodied energy materials in buildings: A review. *Renewable and Sustainable Energy Reviews*. 23, 536-542.
- Carlos, G.D., Correia, M., Dipasquale, L., Guillaud, H., Mecca, S., Mileto, C., Vegas, F., Achenza, M., Viana, D., Cannas, L., 2015. Research method and operative approach, in: Correia, M., Dipasquale, L., Mecca, S. (Eds.), *VERSUS, HERITAGE FOR TOMORROW: Vernacular Knowledge for Sustainable Architecture*. DIDA Dipartimento di Architettura Università degli Studi di Firenze, Firenze, pp. 23 - 31.
- Coelho A, de Brito, J., 2012. Influence of construction and demolition waste management on the environmental impact of buildings. *Waste Management*. 32 (3), 532-41.
- Correia, M., Dipasquale, L., Mecca, S. (Eds.), 2015. *VERSUS, HERITAGE FOR TOMORROW: Vernacular Knowledge for Sustainable Architecture*. DIDA Dipartimento di Architettura Università degli Studi di Firenze, Firenze.
- Correia, M., Juvanec B., Mileto C., Vegas F., Gomes F., Alcindor M., Lima A., 2015. Socio-economic sustainability, in: Correia, M., Dipasquale, L., Mecca, S. (Eds.), *VERSUS, HERITAGE FOR TOMORROW: Vernacular Knowledge for Sustainable Architecture*, DIDA Dipartimento di Architettura Università degli Studi di Firenze, Firenze, pp. 57-63.
- Crishna, N., Banfillb, P.F.G., Goodsira, S., 2011. Embodied energy and CO<sub>2</sub> in UK dimension stone. *Resources, Conservation and Recycling*. 55, 1265- 1273.
- Dayaratne, R., 2010. Reinventing traditional technologies for sustainability: Contemporary earth architecture of Sri Lanka. *Journal of Green Building*. 5 (4), 23-33.
- European Commission. 2014. *The Roadmap to a Resource Efficient Europe (COM (2011) 571)*. Online Resource Efficiency Platform (OREP).  
[http://ec.europa.eu/environment/resource\\_efficiency/about/roadmap/index\\_en.htm](http://ec.europa.eu/environment/resource_efficiency/about/roadmap/index_en.htm) (accessed February 2016)

- Fernandes, J., Mateus, R., Bragança, L. 2014. The potential of vernacular materials to the sustainable building design, in: Correia, M., Carlos, G. D., Rocha, S. (Eds.), *Vernacular Heritage and Earthen Architecture: Contributions for Sustainable Development*. Taylor & Francis Group, London, pp. 623-629.
- Gavrilović, P. 2006. Cultural Heritage in Danger, in: Gavrilović, P., Šumanov, L. (Eds.), *Report of Regional Expert Meeting on Cultural Heritage Protection Through Regional Cooperation in Education, Transfer of Knowledge and Technology*, Skopje-Ohrid, R.M., pp. 6- 8.
- Grabrijan, D., 1986. Macedonian house or transition from old Oriental to modern European house. Mislá, Skopje. (in Macedonian)
- Guillaud, H., 2015. Socio-cultural sustainability in vernacular architecture, in: Correia, M., Dipasquale, L., Mecca, S. (Eds.), *VERSUS, HERITAGE FOR TOMORROW: Vernacular Knowledge for Sustainable Architecture*. DIDA Dipartimento di Architettura Università degli Studi di Firenze, Firenze, pp. 49-55.
- Hadžieva Aleksievska, J., 1985. Measures, Anthropomorphism and modular proportions in the old Macedonian house. *Studentski zbor*, Skopje. (in Macedonian)
- ICOMOS, 1980. *Advisory Body Evaluation*. UNESCO, Paris.
- Innes, S., 2004. Developing tools for designing out waste pre-site and on-site. *Proceedings of Minimising Construction Waste Conference: Developing Resource Efficiency and Waste Minimisation in Design and Construction*. London: New Civil Engineer.
- John, G., Clements-Croome, D., Jeronimidis, G. 2005. Sustainable building solutions: a review of lessons from the natural world. *Building and Environment*. 40, 319-328.
- Kim, J.J., Righton B., 1998. *Sustainable Architecture Module: Introduction to Sustainable Design*. National Pollution Prevention Center for Higher Education, College of Architecture and Urban Planning, The University of Michigan. Michigan:
- Kosmopoulos P., Georgiadou D., 2012. Survey regarding control and reduction of construction waste, in: *PLEA 2012 Proceedings*. <http://www.plea2012.pe/pdfs/T05-20120130-0006.pdf> (accessed September 2014)
- Latham, D., 2000. *Creative Re-use of Buildings I & II*. Donhead, Dorset.
- Lyle, J. T., 1994. *Regenerative design for sustainable development*. John Wiley & Sons Inc., New York.
- Melià, P., Ruggieri, G., Sabbadini, S., Dotelli, G., 2014. Environmental impacts of natural and conventional building materials: a case study on earth plasters. *Journal of Cleaner Production*. 80, 179-186.
- Morel, J.C., Aubert, J.E., Millogo, Y., Hamard, E., Fabbri, A., 2013. Some observations about the paper "Earth construction: lessons from the past for future eco-efficient construction" by F. Pacheco-Torgal and S. Jalali. *Construction and Building Materials*. 44, 419-421.
- Moutsopoulos, N.C., Pavlowitch, D. St., Anguelova, R., Sezgin, H., Stoica G., 1985. *L'Architecture Vernaculaire Dans Les Balkans, Études et documents sur le Patrimoine Cultural – 10*. UNESCO (CLT-85/WS/48). (in French) <http://unesdoc.unesco.org/images/0006/000688/068880fb.pdf> (accessed August 2016)
- Muličkoski, P. 2000. *The creative spirit of the Macedonian house: Genius loci*, Book 1. AEA Izdavači, Skopje. (in Macedonian)

- Nikoloska, M., 2007. The Condition of the Old City Districts on the Territory of the Republic of Macedonia, in: Popović-Živančević M. (ed.), Proceedings of the Regional Conference Protection of the Cultural Heritage, Condition of the Cultural and Natural Heritage in the Balkan Region, Vol. 1., Kladovo, Serbia, pp. 409-421.
- N. U. Zavod za Zaštita na Spomenicite na Kulturata i Muzej – Ohrid, 2010a. Study on the revalorization of the house of Urania - Ohrid. N.U. Zavod i Muzej – Ohrid, Ohrid. (in Macedonian)
- N. U. Zavod za Zaštita na Spomenicite na Kulturata i Muzej – Ohrid, 2010b. Study on the revalorization of the old town of Ohrid]. Н.У. Завод и Музеј – Охрид, Охрид. (in Macedonian)
- Oliver, P. (ed) 1997, Encyclopedia of Vernacular Architecture of the World, Cambridge University Press, Cambridge.
- Oikonomou, A., Bougiatioti, F. 2011. Architectural structure and environmental performance of the traditional buildings in Florina, NW Greece. Building and Environment. 46 (3), pp. 669-689.
- Osmani, M., Glass, J., Prince, A.D.F. 2008. Architects' perspectives on construction waste reduction by design. Waste Management. 28, pp. 1147-1158.
- Pacheco-Torgal, F., Jalali, S. 2012. Earth construction: lessons from the past for future eco-efficient construction. Construction and Building Materials. 29, pp. 512-519.
- Papadopoulos, M. 2013. Seismic assessment of traditional houses in the Balkans– Case studies in Xanthi. Journal of Civil Engineering and Science. 2 (3), pp. 131-143
- Peris Mora, E. 2007, Life Cycle, Sustainability and the Transcendent Quality of Building Materials, Building and Environment. 42, pp. 1329-1334.
- Poon, C.S., Yu, A.T.W., Jaillon, L., 2004. Reducing building waste at construction sites in Hong Kong. Construction Management and Economics. 22, pp. 461–470.
- Poon, C.S., Yu, A.T.W. 2002. A Guide for Minimising Construction and Demolition Waste at the Design Stage. The Hong Kong Polytechnic University, Hong Kong.
- Radović, R. 1990. A stimulating, mysterious and a deceptively place of tradition in architecture. Arhitektura i istorija, De re Aedificatoria. 1, 7-24. (in Serbian)
- Radivojević, A., Roter Blagojević, M., Rajčić, A., 2014. The issue of thermal performance and protection and modernisation of traditional half-timbered (bondruk) style houses in Serbia. Journal of Architectural Conservation. 20 (3), pp. 209–225.
- Radivojević, A., Roter Blagojević, M., Rajčić, A., 2012. Preservation of vernacular architecture in Serbia – authenticity versus thermal comfort issue, in: Proceedings of the 8th International Conference on Structural Analysis of Historical Constructions (SAHC), Wroclaw, Poland, pp. 2750-2759.
- Sassi, P., 2006. Strategies for Sustainable Architecture. Taylor & Francis, Oxon.
- Stefanidou, M., Papayianni, I., Pacht, V., 2012. Evaluation of inclusions in mortars of different historical periods from Greek monuments. Archaeometry. 54 (4), pp. 737–751.
- Tomoski, S., 1960. Macedonian folk architecture. Tehnički Fakultet, Institut za narodna arhitektura, Skopje. (in Macedonian)

Tomovska, R., Mickovski, G., Miletić, M., 2014. Analysis of reconstruction, renovation and change of use: House Uranija – Ohrid. *Izgradnja*, vol 1-2, pp. 20-32. (in Serbian)

Tomovska, R., Radivojević, A., 2015. Environmental features of building materials of traditional Ohrid house and their contribution to its human design, in: *Book of conference proceedings, Places and Technologies 2015: Keeping up with technologies to make healthy places*, Nova Gorica, Slovenia, pp. 86-92.

Trca, J. 2004. Protection of architectural unity in the context of new legislation for the protection of cultural heritage, in: *ICOMOS-FORUM, Opstanok na nedvižnosto kulturno nasledstvo vo uslovi na sovremenite predizvici na 21-iot vek*, Skopje, pp. 2-9. (in Macedonian)

UNESCO, 2004a. Cultural Heritage in South-East Europe: Macedonia (Former Yugoslav Republic of), in: *Mission Report 14 -23 Nov. 2004*, Skopje: UNESCO, Series N°4.

[http://portal.unesco.org/fr/files/33770/11598085459Report\\_Macedonia\\_1-24\\_.pdf/Report%2BMacedonia%2B1-24%2B.pdf](http://portal.unesco.org/fr/files/33770/11598085459Report_Macedonia_1-24_.pdf/Report%2BMacedonia%2B1-24%2B.pdf) (accessed July 2010)

UNESCO, 2004b. Action Plan for implementation of The Mostar Declaration. Bosnia and Hercegovina, Mostar: UNESCO.

[http://www.see-heritage.org/first\\_ministerial\\_conference-action\\_plan.pdf](http://www.see-heritage.org/first_ministerial_conference-action_plan.pdf) (accessed July 2010)

UNESCO, 2006. Proceedings: Cultural Heritage a Bridge Towards a Shared Future: Third Ministerial Conference on Cultural Heritage in South-Eastern Europe, Ohrid R.M.

[http://www.see-heritage.org/third\\_ministerial\\_conference\\_ohrid\\_proceedings.pdf](http://www.see-heritage.org/third_ministerial_conference_ohrid_proceedings.pdf) (accessed July 2010)

Ventakarama Reddy, B.V., Jagadish, K.S., 2003. Embodied energy of common and alternative building materials and technologies. *Energy and Buildings*. 35, pp. 129–137.

Yeang, K., 1995. *Designing with nature: The ecological basis for architectural design*. McGraw-Hill, New York.

Zuo, J., Zhao, Z.-Y., 2014. Green building research-current status and future agenda: A review. *Renewable and Sustainable Energy Reviews*. 30, pp. 271-281.

Çelebi, G., 2003. Environmental Discourse and Conceptual Framework for Sustainable Architecture, *Gazi University Journal of Science*. 16 (1), pp. 207 - 214.

Čipčan, B., 1982. *The old urban architecture in Ohrid*. Makedonska kniga, Skopje. (in Macedonian)

**Figure 1.** Examples of traditional Ohrid houses: Traditional Ohrid houses along Hristo Uzunov Street (upper left), Traditional Ohrid house near the Church of St. Sofia (upper right), Traditional Ohrid house on Kliment Ohridski Street (lower left) and on Ilindenska Street (lower right) - photos by the authors

**Figure 2.** The stone masonry of a traditional Ohrid house, stiffened and levelled with wooden lacing called *santrač* -adapted from (Čipan, 1982)

**Figure 3.** The structure of a typical *bondruk* wall of a traditional Ohrid house – by the authors (left); adapted from (Čipan, 1982) (right)

**Figure 4.** The anthropomorphic modular coordination of a traditional Ohrid house - by the authors

**Figure 5.** Horizontal plan of a traditional Ohrid house- by the authors

**Figure 6.** Carved ceilings from the representative salons of Uranija House, Ohrid. The complete ceiling consists of a great number of carved and flat wooden parts, which are assembled according to a previously conceived design/scheme. - photos by the authors

**Figure 7.** Incorporation of treated stone blocks from earlier periods into the stone walls of Ohrid houses- photos by the authors

**Figure 8.** Different treatments of plaster joints and appearance of the massive stone wall of traditional Ohrid houses – Before the joints were treated (left), Concave plaster joints (centre), and Convex plaster joints (right) - photos by the authors

**Figure 9.** Dark painted wooden stitching, typical for the facades of traditional Ohrid houses: House on Ilindenska Street near the antique theatre (top), house of the Robev family (lower left) and house near the Church of St. Sofija (lower right). - photos by the authors

**Figure 10.** Life Cycle Design of traditional Ohrid house - by the authors

**Table 1.** Building materials of traditional Ohrid house (by the authors)

<b>Building material</b>	<b>Basic characteristics and the way material was incorporated</b>
<b>Stone</b>	- used for construction of massive walls; untreated and/or treated stone blocks excavated from the immediate surroundings or from the local quarry; - the treated stone blocks often originated from older buildings and monuments that previously existed at the site;
<b>Wood</b>	- beech or fir wood from the immediate surroundings;
<b>Mud mortar</b>	- the most common binder of the stone walls;
<b>“Čok” plaster</b>	- traditional plaster applied to the exterior surfaces of the <i>bondruk</i> wall; - plaster mixture made of hydrated lime, fine sand, off cuts of timber, and straw or animal fibre;
<b>Lime based plaster</b>	- traditional plaster applied to the interior surfaces of the <i>bondruk</i> wall, made of hydrated lime or dry pulverised lime, river sand, and a small amount of a material with pozzolanic features (ground volcanic stone, powder from clay tiles or pozzolanic earth);
<b>Glass</b>	- glass commonly used in the territory of the Balkans in the 19 <sup>th</sup> and at the beginning of 20 <sup>th</sup> century;
<b>Clay tiles</b>	- made of clay from the immediate surroundings;



**Table 2.** Conceptual framework of sustainable design (based on methodological framework of sustainable design - Kim and Righton, 1998)

Principle: <b>Economy of Resources</b>			
Strategies:	<b>Energy Conservation</b>	<b>Water Conservation</b>	<b>Material Conservation</b>
Methods:	<i>energy conscious urban planning</i>	reuse of water on site	<i>material conserving design and construction</i>
	<i>energy conscious site planning</i>	collection of rainwater and grey water	<i>proper sizing of the building systems</i>
	<i>passive heating and cooling</i>	reduction of consumption and waste	<i>rehabilitation of existing structures</i>
	<i>insulation</i>		<i>use of reclaimed of recycled materials and components</i>
	<i>alternative sources of energy</i>		<i>use of non-conventional products as building materials</i>
	<i>building and window design that utilises natural light</i>		
	energy efficient equipment		
	<i>materials with low embodied energy (natural, local and biodegradable materials)</i>		
Principle: <b>Life Cycle Design</b>			
Strategies:	<b>Pre-Building Phase</b>	<b>Building Phase</b>	<b>Post-Building Phase</b>
Methods:	<i>source reduction by design</i>	minimisation of site impact	adjustment of existing structures to new users and programs
	<i>minimisation of energy needed for distribution of materials</i>	recycling of construction materials and provision for waste separation facilities	<i>reuse of building components and materials</i>
	<i>use of materials made from renewable resources</i>	<i>incorporation of scrap and useful materials found on the site</i>	<i>reuse of existing parts of the building</i>
	use of harvested materials or materials extracted without causing ecological damage	<i>use of building techniques that support energy and material conservation</i>	recycling of building components and materials
	use of recycled materials	<i>use of non-toxic materials and cleaners for protection of construction workers and end users</i>	reuse of land and the existing infrastructure
	<i>use of durable materials with low maintenance</i>		<i>biodegradability of the used materials</i>
<i>use of local, natural and non-toxic materials</i>			
Principle: <b>Humane Design</b>			
Strategies:	<b>Preservation of Natural Conditions</b>	<b>Urban Design and Site Planning</b>	<b>Design for Human Comfort</b>
Methods:	<i>respect of topographical contours</i>	integration of design with public transport	<i>provision for thermal, visual and acoustic comfort</i>
	<i>non-disturbance of natural hydraulic process</i>	promotion of mixed use development	<i>provision for visual connection with exterior</i>
	<i>preservation of existing flora and fauna</i>	<i>avoidance of pollution contribution</i>	<i>provision for operable windows</i>
			<i>provision for fresh clean air</i>
			<i>use of non-toxic and non-outgassing materials</i>
		accommodation of persons with different physical abilities	

Notes:

1. Sustainable methods implemented in the example of the traditional Ohrid house are marked in italics;
2. Sustainable methods that are in correlation with the re-use of building materials and the minimisation of construction waste are highlighted in grey.



ACCEPTED MANUSCRIPT

**Table 3.** Sustainable - “green” features of building materials of Ohrid traditional house (by the authors)

Building Phase	Criteria	Building material						
		Stone	Wood	Clay tiles	Mud mortar	“Čok” plaster	Lime based plaster	Glass
Pre-building phase: <b>Manufacture</b>	pollution prevention	+	+	+	+	+	+	
	embodied energy reduction	+	+	+	+	+	+	
	use of natural and/or naturally based materials	+	+	+	+	+	+	+
	recycled content					+	+	
	waste reduction	+	+		+	+	+	
Building phase: <b>Use</b>	reduction in construction waste	+	+	+	+	+	+	
	use of local materials	+	+	+	+	+	+	
	energy efficiency	+						
	use of non-toxic or less-toxic materials	+	+	+	+	+	+	+
Post-building phase: <b>Disposal</b>	durability	+						
	reusability	+	+	+				
	recyclability		+	+				+
	biodegradability		+	+	+	+	+	

Note: + (“plus”) – refers to the presence of a “green feature” in a building material

**Table 4.** Modern versus vernacular building practices in the Old town of Ohrid regarding the implementation of green features (by the authors)

	<i>Modern building practice</i>	<i>Vernacular building practice</i>
<i>Green feature</i>		
<b>Choice of building materials</b>	frequent use of modern, mass produced materials (bricks, clay blocks, lightweight concrete blocks, concrete, etc.)	Traditional local, natural or handcrafted materials
<b>Source reduction by design - standardisation and modular coordination</b>	partially applied on the level of materials and products, not on the level of the structure or building as a whole	applied
<b>Incorporation of scrap and useful materials found on site</b>	not applied	applied
<b>Reuse of building components and materials</b>	scarcely applied	applied
<b>Reuse of existing parts of the building</b>	not applied	applied
<b>Recycling</b>	not applied	not typical for the time

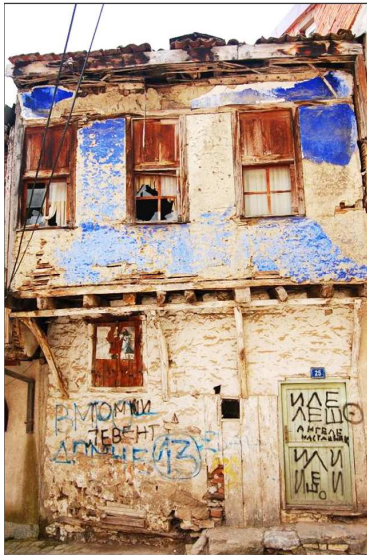

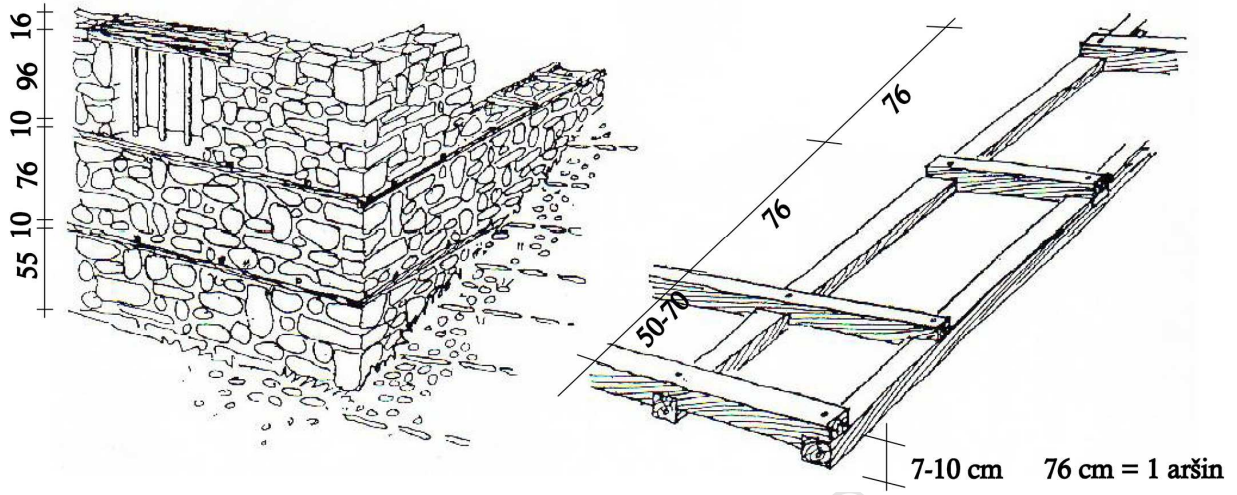

ACCEPTED MANUSCRIPT

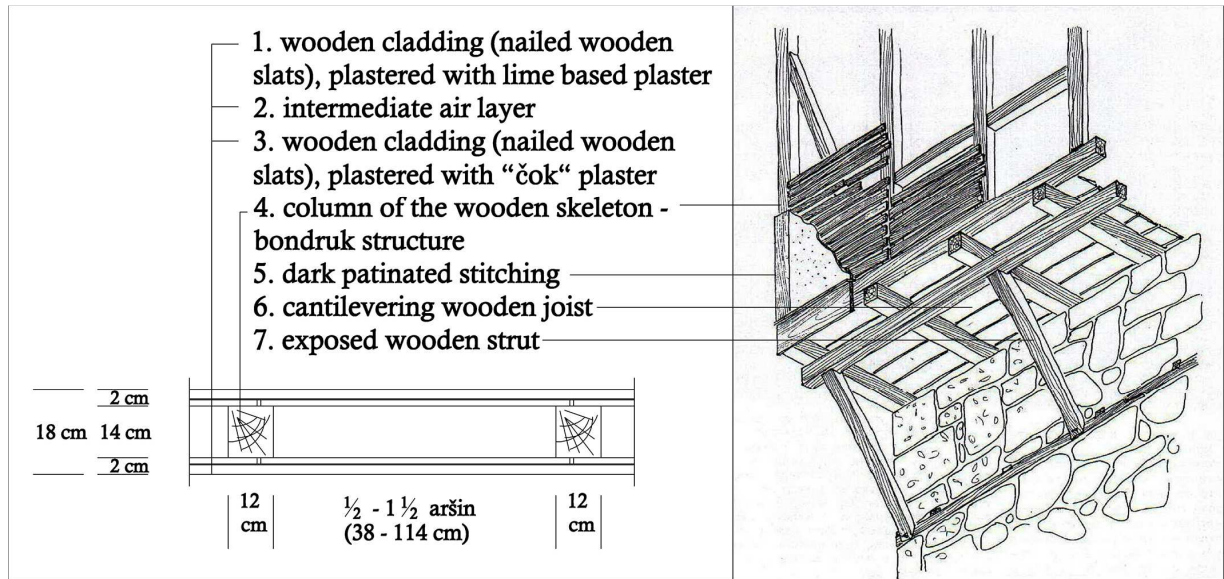

Modular grid of the bondruk system - second floor

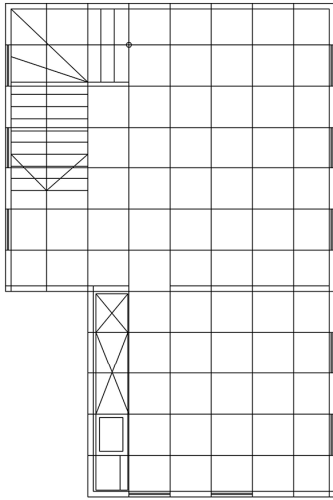

1 Modul = 1 x 1 aršin  
1 aršin = 76 cm

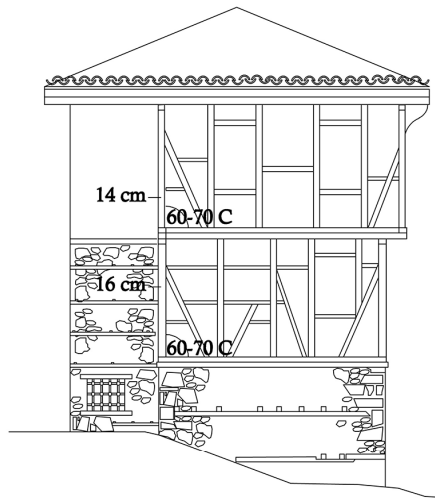

MASIVE PART BONDruk PART OF THE HOUSE

$$\begin{aligned}
 &h = \frac{1}{3} - \frac{1}{2} \text{ aršin} \\
 &H = 3 \frac{2}{3} - 4 \text{ aršin} \\
 &h = \frac{1}{3} - \frac{1}{2} \text{ aršin} \\
 &H = 3 \frac{1}{3} - 3 \frac{1}{2} \text{ aršin} \\
 &h = \frac{1}{3} - \frac{1}{2} \text{ aršin} \\
 &H = 2 \frac{1}{2} - 3 \text{ aršin}
 \end{aligned}$$

Ground and first floor = 5  $\frac{1}{2}$  aršin

Second floor = 6 aršin

ACCEPTED MANUSCRIPT



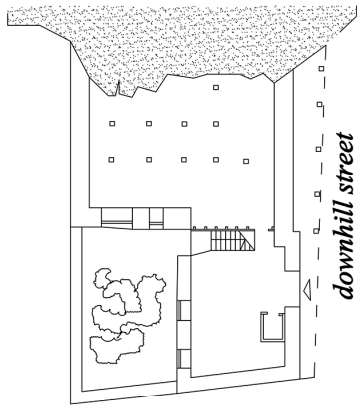

*basement + yard  
down floor*

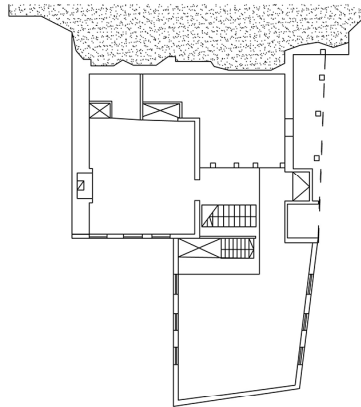

*winter dwelling  
mezzanine*

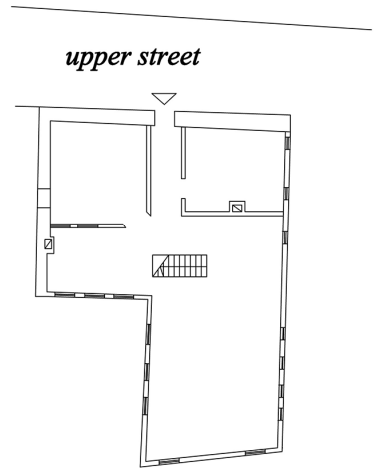

*summer dwelling  
upper floor*

0 5 m

ACCEPTED MANUSCRIPT

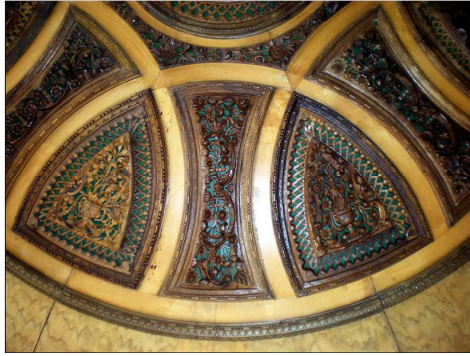

ACCEPTED MANUSCRIPT



ACCEPTED MANUSCRIPT



ACCEPTED MANUSCRIPT



## LIFE CYCLE DESIGN OF TRADITIONAL OHRID HOUSE

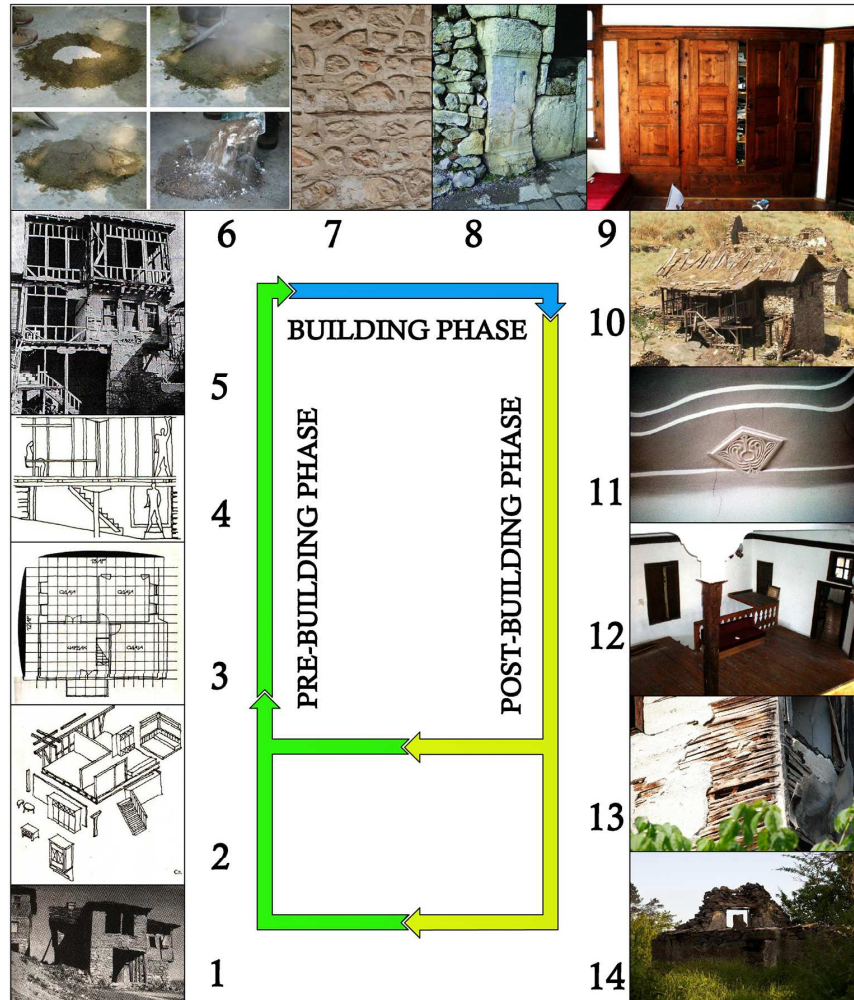

1. Local, natural and non-toxic materials - Buildings stem out of the ground
2. Design for reuse
3. Modular coordination in the proces of design (standardization and type-sorting of elements of construction and finalization
4. Proper sizing of the building systems
5. "Elasticity" - flexibility of the building: Possibility of changing the spatial plan, as well as replacement of the deteriorated material of the bondruk system
6. Incorporation of waste, as well as the scrap material, in production of new usefull building materials, at the construction site
7. Building techniques that enable waste prevention and source reduction
8. Durable materials with low maintenance
9. Wood protection and extending it's durability with natural resources
10. Reuse of existing parts of the building
11. Recycled content feature - Building materials produced partialy from construction waste (the traditional plasters)
12. Reuse of building components and materials
13. Biodegradable building materials
14. After the end of the building's life cycle, building goes back to earth.

**Highlights:**

- The principle of anthropometric modular coordination was typical for traditional Ohrid houses
- The applied modular coordination allowed the reuse of building elements
- Flexible design and material basis reveal the natural cycle of a traditional Ohrid house
- The prudent and rational work of the traditional builder is today understood as sustainable