

POSSIBILITIES FOR THE USE OF GEOTHERMAL ENERGY IN NEW RESIDENTIAL BUILDINGS IN SERBIA, CASE STUDY Urban Blocks in City of Kragujevac

by

Nikola M. MACUT*, **Milica D. JOVANOVIĆ POPOVIĆ**,
and Snežana M. ANDRIĆ

Faculty of Architecture, University of Belgrade, Belgrade, Serbia

Original scientific paper
<https://doi.org/10.2298/TSC170602221M>

Use of RES is an important element for achieving ambitious results for CO₂ emission reduction in EU, emphasized and obligated by RES Directive, among other documents. In Serbia, as a candidate country and a signatory of Energy treaty, targets set by relevant documents reflect in benchmarks set by National Action Plan for Energy Efficiency, setting the level of reduction of energy consumption until 2018 for 9%, with more ambitious projections up to 2030. This calls for extensive research of possibilities for the use of renewable energy in buildings, its potentials and possible restrictions. Since the Directive states that low amount of energy required should be covered to a very significant extent by energy from renewable sources, including energy from renewable sources produced on-site or nearby, an investigation of possibilities for application of geothermal ground probes for a typical residential urban block in the city of Kragujevac is presented. This enables analysis of limitations imposed by legal and physical conditions: planning guidelines, type of ground, functional requests and infrastructural capacities. Typology of characteristic urban block layouts for residential buildings is generated, leading to projections of possible area covered with ground probes and calculations of relevant energy needed for heating, based on current regulations on energy efficiency in buildings. From these calculations, percentage of defined energy needs from possible geothermal ground probes is defined, enabling estimation of geothermal energy potential for new residential building blocks.

Key words: *energy efficiency in buildings, renewable sources, geothermal energy, residential buildings, urban block*

Introduction

Today, the question of RES becomes one of the most important in case of CO₂ emission reduction. Republic of Serbia, through Action Plan for Energy Efficiency on national and local level, supports the use of RES for producing electrical and thermal energy [1]. Geothermal energy, as a type of RES, in Serbia according to National Action Plan for Use of Renewable Energy Sources have a part in installing additional 1092 MW of electrical energy by the participation of 7 GWh for assumed time of 7000 working hours. That fact presents that the participation of geothermal energy sources is only 0.2% of whole production of electrical energy [2]. However, Serbia is noticeably rich with hydrogeothermal sources which are not

* Corresponding author, e-mail: nikola.macut@arh.bg.ac.rs

properly in use. In Serbia more than 150 springheads exist. The temperatures of water are most often between 15 °C and 90 °C [3]. Geothermal sources are estimated to the equivalent amount of $400 \cdot 10^6$ tons of oil, while the total estimated heat power of underground water which demand the use of heat pumps is 2300 MW [4]. In this paper, city of Kragujevac, Serbia is analyzed as a case study in order to establish the methodological principle which can be used in the process of urban planning later on, as well as in other cities. According to the evaluation of geothermal potentials of Central and Western regions of Serbia, where Kragujevac is situated, available geothermal heat power is estimated on approximately 1100 MW [4]. This indicator confirms the fact of possible use of vertically installed ground-source probes for producing heat energy. The systems of ground source probes today present efficient systems because probes are installed in deeper parts of the ground where temperatures are constant [5]. Levels of temperatures varies because of different types of soils and different levels underground. Before installing probes, it is necessary to do some research which includes: defining of hydrogeological characteristics, measuring of the groundwater temperature, evaluation of possibilities of the geothermal resource use for cooling/heating, environmental, and economic aspects [6].

Urban parameters of urban blocks

In Serbian urban and architectural practice, spatial and volumetric characteristics as well as capacities of urban structures are determined by the legal documents like General and Detailed plans of specific area. When the city of Kragujevac is in question, urban parameters for the central part of the town are defined in the General regulation plan adopted in 2014. (*Plan generalne regulacije "Centar – Stara Varoš"*) [7]. For the purpose of this research, two urban residential blocks, whose transformation through new developments is planned, were analyzed: residential blocks E.3.8 and E.3.6 with zones A 2.1 and A 2.2., fig. 1. Those two blocks were chosen as typical according to the area, planned gross area and planned number of inhabitants. Urban characteristics of the blocks are summarized in tab. 1. By summarizing those parameters with other parameters of all lots it was possible to make three different types of lots for case study analysis.



Figure 1. Analyzed urban blocks in city of Kragujevac

Table 1. Urban parameters of analyzed urban blocks

Blocks	E.3.6	E.3.8
Number of lots	16	17
Area of the lots [m]	306-679	349-935
Floor area ratio	1.6-2.6	1.6-3.0
Gross floor area per lot [m]	489.60-1765.40	558-3225

Typology of buildings and lots in blocks

In this paper are presented three typical types of lots in those selected blocks. For this purpose all lots from two blocks are sorted in three groups, thus there are lots with areas lower

than 400 m², lots with areas in interval from 400 m² to 600 m² and lots larger than 600 m². Before defining three different types of lots the most important step was to make a selection where it was possible to make one large view of different types of lots in those blocks. After that it was possible to put together lots in defined groups. Defined groups by their area size have one representative which was taken by getting arithmetic mean from all lots which were placed in certain group. Results of this kind of calculation are presented as representatives of different types of lots so it was possible to done other steps od this analysis. As the results of mentioned calculation of getting arithmetic mean for this purpose are given three types of lots. It is necessary to mention that for this purpose the buildings are defined with the lot coverage which is not the highest possible for those blocks according to the urban parameters. For this paper lot coverages are lower than defined ones so the free spaces in backyards of lots could be larger in case of placing ground source probes. Three types of defined lots have their own subtypes A and B, which are only different by the type of underground garage and its area. Parameter of garage area is also one of the most important for probes distribution in the soil of backyards.

Table 2. Urban parameters of defined types and subtypes of lots and residential buildings

	Type 1A	Type 1B	Type 2A	Type 2B	Type 3A	Type 3B
Lot area [m ²]	361.3		476.54		706.79	
Lot dimensions [m]	13.95 × 25.90		15.89 × 29.99		23.06 × 30.65	
Dimension of building [m]	13.95 × 10.36		15.89 × 13.49		23.06 × 15.94	
Floor area [m ²]	433.56		643.33		1378.24	
Gross floor area [m ²]	578.08		857.77		1837.65	
Floor area ratio	1.6		1.8		2.6	
Lot coverage [%]	40		45		52	
Garage area [m ²]	200	120	275	180	500	300

Type 1 in fig. 2 is the smallest lot with area of 361.3 m². By the urban parameters for this location is possible to build new building with ground floor and three more floors. Dimensions of building are derived from arithmetic mean and gross floor area, floor area, floor area ratio and the lot coverage for this type are presented in tab. 2. Although for this lot is possible to have lot coverage 60% from the given urban parameters in this case buildings are designed with the lot coverage of 40%. This type of building has seven flats and one shop for rent so it has eight parking places in underground garage. Type 1A have garage with area of 200 m² with dimensions 13.95 m × 14.33 m. Type 1B has garage area of 120 m² with dimensions 13.95 m × 8.60 m. Difference between subtypes and their areas is that 1A has classic garage (one car at one parking

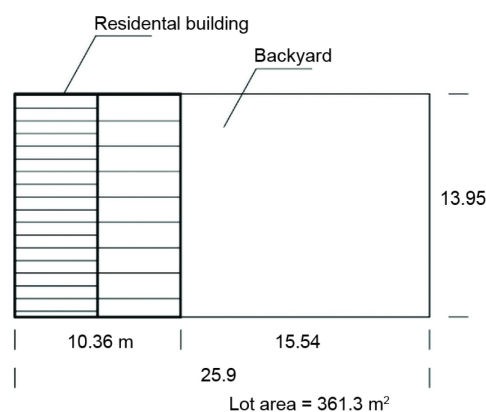

Figure 2. Lot Type 1

place). Type 1B has a classic garage (one car at one parking

place) on one floor and other 1B have park-boxes thus two cars can be parked one on another at one parking place.

Type 2 in fig. 3 is the medium lot by the area of 476.54 m² and with dimensions of 15.89 m × 29.99 m, thus on this lot it is possible to build new residential building with height of four floors where ground floor is included. New building has dimensions 15.89 m × 13.49 m and lot coverage is 45%. Building is designed by the use of smaller lot coverage although the highest coverage could be 60% according to the urban parameters. In tab 2. gross floor area, floor area, floor area ratio, and the lot coverage are presented for this type of defined lot. Type 2 has 9 flats and 2 shops for rent, so it has 11 parking places which are different arranged in the subtypes. Type 2A has garage area of 275 m² with dimensions 15.89 m × 17.30 m, Type 2B with park-boxes has area of 180 m² with dimensions 15.89 m × 11.32 m.

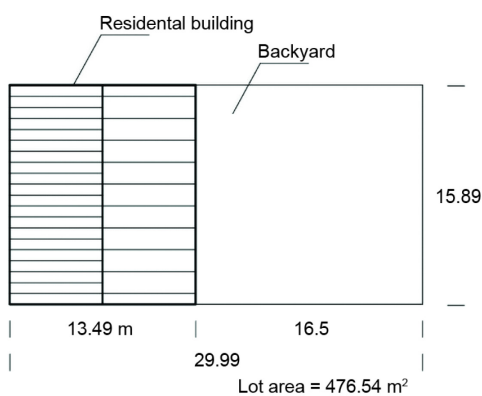

Figure 3. Lot Type 2

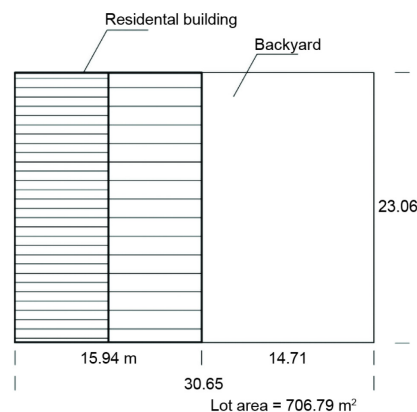

Figure 4. Lot Type 3

Type 3 in fig. 4 is the largest type of lot with area of 706.79 m². Dimensions of lot are 23.06 m × 30.65 m and building can maximum have five floors (ground floor is included). Dimensions of defined building are 23.06 m × 15.94 m. This lot presented in tab. 2. has the largest gross floor area, floor area ratio and lot coverage which is 52% out of 60% as the largest possible lot coverage. Type 3 is defined as building with 18 flats and 2 shops for rent, so it has 20 parking places in underground garage. Type 3A has area of 500 m² with dimensions 23.06 m × 21.68 m, and Type 3B with park-boxes has area of 300 m² with dimensions 23.06 m × 13 m.

Possibilities of installation of ground-source probes

On the three different lots it is possible to place ground-source probes [8] in many different ways, depending the lot area, lot coverage, and garage area. In this paper are presented two ways of placing probes in the ground depending of the area of underground garage which occupies a part of the lot area. Before the explanation of possibilities of installation of ground probes it was necessary to emphasize that for this purpose ground probes are only placed in the free spaces of lots. Also, the parameter of distribution was that probes are not placed under the parts of buildings or under the whole building, but only in the already mentioned free spaces of the backyards. Three different types of lots by their dimensions gave us different possibilities for probes distribution. The most important parameter for placing probes in the ground is the free space around the probe. Each probe have the operational range, re-

garding the space from which one probe takes geothermal energy. Probes which are taken for this analysis have a operational range in diameter of 7 m [9]. It is also important to mention that ground-source probes for this analysis have maximum length of 100 m in the ground. With those parameters and with the free area of lot is possible to place probes. Already mentioned underground garages are also the key parameters for probes distribution in the ground.

As it was defined, three types of lots Type 1, Type 2, and Type 3 with their subtypes Type 1A, Type 1B, Type 2A, Type 2B, Type 3A, and Type 3B have their own ways of placing probes in the ground. Type 1A has possibility of placing only two probes in the free backyard space because the underground garage have the area larger than the building above-ground so there is not enough space for placing more probes. The possibility of distribution of two probes with length of 100 m is presented in fig. 5. Type 1B in fig. 5 has better capacity for probes distribution so it has possibility of placing 4 probes, because underground garage do not occupy larger area than the above-ground area of building, on a contrary it occupies smaller area than the above-ground.

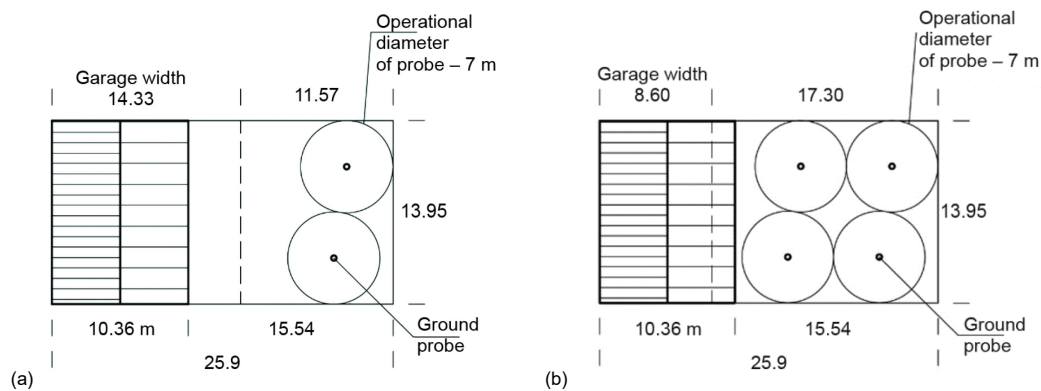

Figure 5. Positions of probes, (a) Type 1A, (b) Type 1B

Type 2A in fig. 6 with its dimensions and free area has a space for placing three probes with length of 100 m of each one in case when the underground garage area is larger than above-ground. However, Type 2B has better capacity for probes distribution, because in this case four ground-source probes can possibly be placed in order in the free backyard space where underground garage does not have larger area then above-ground, as presented in fig. 6.

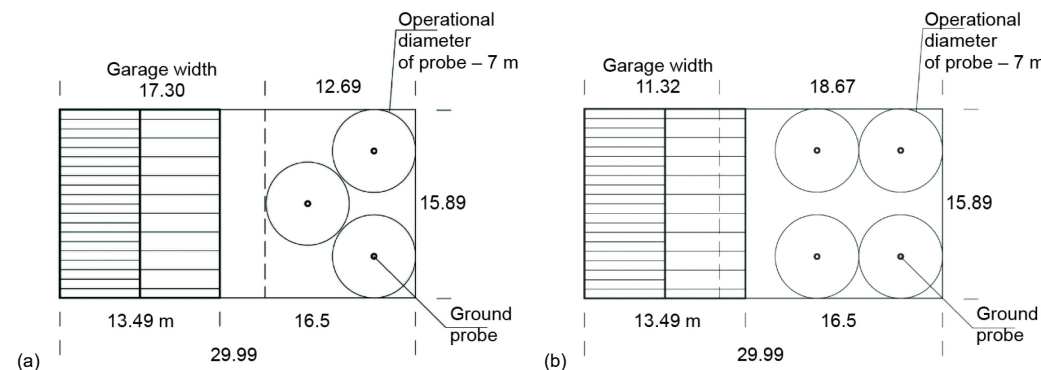

Figure 6. Positions of probes, (a) Type 2A, (b) Type 2B

The largest types of lots Type 3A and Type 3B in fig. 7 also have difference in possibilities of probes distribution. Type 3A has only one row which consists of three 100 m long probes. Instead of that Type 3B has better capacity for probes distribution. In this case is possible to make two rows which consist of three 100 m long ground-source probes so the maximum number of probes are six for this type of lot.

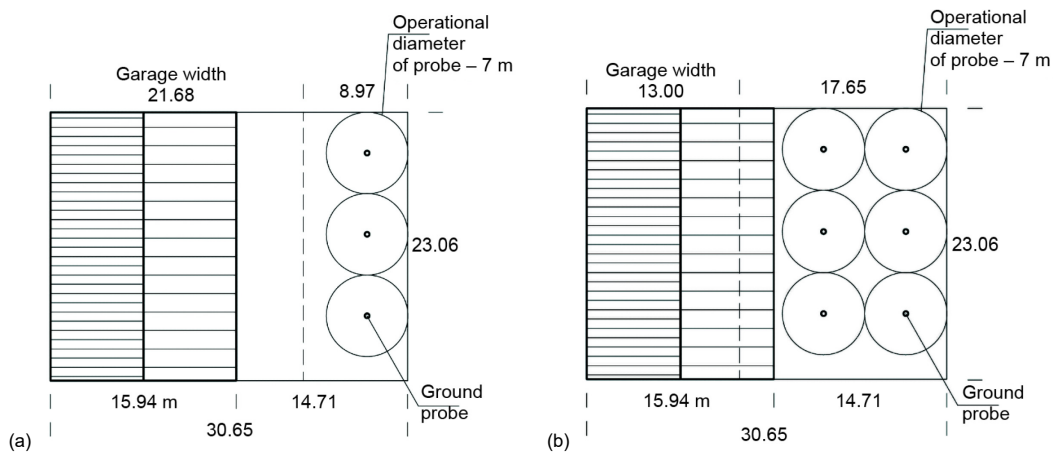

Figure 7. Position of probes, (a) Type 3A, (b) Type 3B

Calculation

As a final step of analysis in this paper is calculation of possibly obtained heat power from the geothermal sources with the use of ground-source probes. First parameter of calculation is already mentioned length of the each probe which is 100 m. Second parameter is the specific heat extraction which is specific extraction output of the probe depending on the soil type. In already mentioned General regulation plan one chapter of plan have the list of geological zones. Those geological zones have soil which consists sandstones, and in some parts have expressed presence of gravel and sand. Level of the underground water varies from the depth of 2 m to 6 m, but in the most cases level of underground water is on 4 m depth from the ground surface. On the basis of those soil type parameters specific extraction output

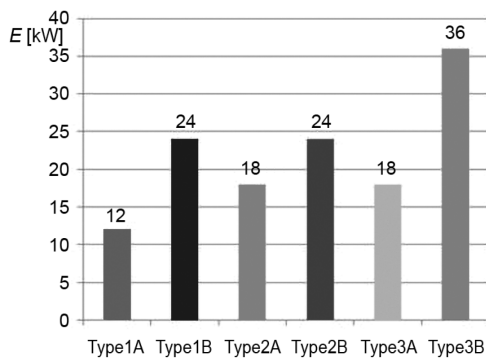

Figure 8. Summarized results of calculation

of the ground – source probe must be chosen for further calculation. The amount of the output of the ground varies from 25-80 W/m and it directly depends of the composition of the ground [5]. For this paper and in case of ground composition in area of city of Kragujevac the amount of 60 W/m [9] is chosen as unique for two blocks. With mentioned parameters is possible to take calculation by mathematical expression, tab. 3:

$$E = n L S H E \quad (1)$$

Results of calculations are summarized in fig. 8 which presents differences between two

ways of probes distribution in the soils of defined lots in urban blocks in Kragujevac. The differences between the possibilities of probes distribution is in direct relation with dimensions of underground garage spaces and their areas.

Table 3. Results of calculation of heat power for analyzed lot types

Lot type	Number of probes, <i>n</i>	Probes length, <i>L</i> [m]	Specific heat extraction, <i>SHE</i> , [Wm ⁻¹]	Heat power, <i>E</i> , [kW]
Type 1A	2	100	60	12
Type 1B	4	100	60	24
Type 2A	3	100	60	18
Type 2B	4	100	60	24
Type 3A	3	100	60	18
Type 3B	6	100	60	36

Possibilities of covering heat losses in buildings by use of probe heat power

For analyzing possibilities for covering heat losses by use of probe heat power it was necessary to do calculation in three steps. Formulas for calculation and methodology require specific inputs. In the case of analyzed residential buildings all of them were designed as new buildings which can be put by their performances in energy class C, with heat losses $Q = 60 \text{ kWh/m}^2\text{a}$ [10]. First step is related to the calculation of specific heat losses for each analyzed building. Second step presents calculation of temperature's differences. Final third step is the most important step because it presents the possibilities of covering heat losses by the use of probe's heat power for each lot and building and it is percentage of covering heat losses.

Calculation of specific heat losses of analyzed residential buildings

Presented parameter $Q = 60 \text{ kWh/m}^2\text{a}$ is one of the main inputs for calculation. Also heating degree days is important input for needed calculation. According to the Regulation for Energy Efficiency in Serbia, heating degree days in Kragujevac are presented with the value of $HDD = 2610$ [10]. It is also necessary to present other parameters. For this purpose, heated area is also important parameter. Other input is related to the parameter of time which is for this occasion presented with the value of $t = 24$ hours. With all needed inputs following mathematical expression is formed so the specific heat loss could be calculated:

$$AQ = \frac{H HDD t}{1000} \quad (2)$$

Results of calculation are presented in tab. 4. Through the presented table it is possible to notice the same values of the same types and subtypes of buildings. Those values are later in use in the final step of calculation in this paper.

Calculation of themperature differences

Temperatures as parameters for analysis and calculation are specific for each region in Serbia. In this paper, for the purpose of calculation the estimate temperature in Kragujevac

Table 4. Parameters and results of calculation for Specific heat loss, H [WK^{-1}]

Lot type	Floor area, A , [m^2]	Energy class C, Q [kWhm^{-2}]	Heating period, t [h]	Heating degree days, HDD	Specific heat loss, H [WK^{-1}]
Type 1A	433.56	60	24	2610	415.29
Type 1B	433.56	60	24	2610	415.29
Type 2A	643.33	60	24	2610	616.22
Type 2B	643.33	60	24	2610	616.22
Type 3A	1378.24	60	24	2610	1320.15
Type 3B	1378.24	60	24	2610	1320.15

as the city in the central part of Serbia is $T_e = -15$ °C [10]. Beside this parameter average temperature $T_a = +5.5$ °C, and estimate interior temperature $T_i = +20$ °C were inputs for mathematical expressions.

Equation (3) is related to the differences between estimate interior temperature, T_i , and average temperature, T_a :

$$\Delta T_1 = T_i - T_a \quad (3)$$

Second mathematical expression, eq. (4), presents the differences between estimate interior temperature and estimate temperature in Kragujevac:

$$\Delta T_2 = T_i - T_e \quad (4)$$

The result $\Delta T_2 = 35$ °C of eq. (4) is used for further calculation and presents the input for calculation of needed heat energy for heating system in regard to the estimate temperature in Kragujevac which was in use as input for mentioned equation.

Calculation of needed heat energy for heating systems in residential buildings

Needed heat energy with its results is the main and also the final step of analysis throughout this paper. In case of getting needed results already calculated specific heat losses, H , eq. (2) and temperature differences, ΔT_2 , eq. (4). It is important to mention that for this paper needed heat energy is only calculated by the use of estimate temperature in Kragujevac, T_e , eq. (4). Results of calculation are presented in tab. 5. The following mathematical expression was in use:

$$Q = H \Delta T_2 \quad (5)$$

The final step of analysis is defined as presentation of percentage of covering heat losses for the specific types of buildings by the use of heat power from ground source probes. This percentage is defined through the simple mathematical expression. Equation (6) presents the percentage of covering heat losses without losses which can exist in specific heating system of residential buildings.

$$P1 = \frac{E}{Q} \quad (6)$$

In eq. (7) losses in heating systems are included so the heat power from the ground source probes is reduces for 10% thus formula is defined as:

Table 5. Results of needed heat energy

Lot type	Specific heat loss, H [WK^{-1}]	Temperature differences, ΔT_2 [$^{\circ}\text{C}$]	Needed heat energy [kW]
Type 1A	415.29	35	14.54
Type 1B	415.29	35	14.54
Type 2A	616.22	35	21.57
Type 2B	616.22	35	21.57
Type 3A	1320.15	35	46.21
Type 3B	1320.15	35	46.21

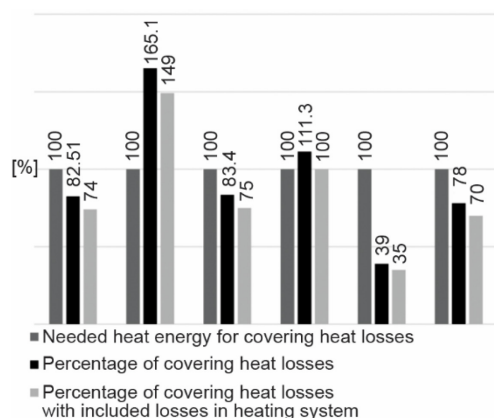

Figure 9. Results of final calculation expressed in percents

garages and their areas and also lot areas, lot coverages are important parameters for installation of probes. The results given by the calculations presents different capacities of lots, different number of possibly installed probes in case when probes are only placed in the free space of backyard ground and not under the buildings. This case study presented methodology of probes installation, which is the simplest method of the use of ground-source probes. Methodology and further calculation presented different results which are in direct relation to the urban parameters. It is necessary to emphasize that urban parameters and possibilities of probes distribution in the ground gave to us numerous results throughout calculation. The results goes from the values which are under the half of needed heat power to the values which are above 100% of needed heat power for covering heat losses in the specific buildings. Whole three steps of calculation present that different parameters-inputs gave to us different results and that every lot have some specific differences in comparison to other lots. In case of more efficient use of probes as another method is possible to install probes under the foundation of building as energy piles so the whole lot can be covered by probes for more efficient derivation of geothermal energy. This method can only be the second step of efficient use of probes and guidelines for further analysis of the use of geothermal energy in case when there is not enough space in backyards for probes installation.

$$P2 = \frac{E \cdot 0.9}{Q} \quad (7)$$

Final step of calculation in case of presenting possibilities of the use of geothermal energy is presented in fig. 9 with final results in cases when losses in heating systems were not included and when losses in heating systems were included.

Conclusion

Throughout different types of analysis in this paper it is obvious that urban parameters dictate possibilities of use of ground-source probes in different types of lots in urban blocks with regards to different design of underground

Nomenclature

A	– heated area, [m ²]	t	– heating period [hour]
E	– heat power, [kW]	T_a	– average temperature, [°C]
H	– specific heat loss, [WK ⁻¹]	T_e	– estimate temperature in Kragujevac, [°C]
HDD	– heating degree days	T_i	– estimate interior temperature, [°C]
L	– probes length, [m]	ΔT_1	– difference in temperature between estimate interior temperature and average temperature, [°C]
n	– number of probes	ΔT_2	– difference in temperature between estimate interior temperature and estimate temperature in Kragujevac, [°C]
$P1$	– percentage of covering heat losses		
$P2$	– percentage of covering heat losses with reduction of heat power		
Q	– heat loss, [kWh/m ⁻¹ per year]		
SHE	– specific heat extraction, [Wm ⁻¹]		

References

- [1] ***, Second Action Plan for Energy Efficiency of Republic of Serbia for the Period from 2013, until 2015 (in Serbian), *Official Gazette of Republic of Serbia*, no. 98/2013, Belgrade, 2013
- [2] ***, National Action Plan for the Use of Renewable Energy Sources of Republic of Serbia (in Serbian), *Official Gazette of Republic of Serbia*, no. 53/2013, Belgrade, 2013
- [3] Šušteršič, V., et al., An Overview of Regulatory Framework for the Geothermal Energy in Europe and Serbia, *Thermal Science*, 14, (2010), Suppl., pp. S115-S123
- [4] Milenić, D., et al., Hydrogeothermal Resources as Factors of Development of Serbia, Importance of Geothermal Waters for the Serbian Economy (in Serbian), Serbian Academy of Science and Arts – Board for Rural Issues, Lukovska Banja, Serbia, 2014
- [5] Čenejac, A., et al., Covering of Heating Load of Object by Using Ground Heat as a Renewable Energy Source, *Thermal Science*, 16 (2012), Suppl. 1, pp. S225-S235
- [6] Vranješ, A., et al., Geothermal Concept for Energy Efficient Improvement of Space Heating and Cooling in Highly Urbanized Area, *Thermal Science*, 19 (2015), 3, pp. 857-864
- [7] ***, First Substitution and Addition of General Regulation Plan “Center – Old Town” (in Serbian), PUC Directorate for Urbanism, Kragujevac, Serbia, 2014
- [8] ***, Rehau, <https://www.rehau.com/gb-en/building-technology/renewable-energy/ground-source-energy/probes-pipework/raugeo-pe-xa-probes>
- [9] ***, Rehau, <https://www.rehau.com/download/790486/raugeo-technical-manual-september-2012.pdf>
- [10] ***, Regulation for Energy Efficiency of Buildings (in Serbian), *Official Gazette of Republic of Serbia*, no. 61/2011, Belgrade, 2011